

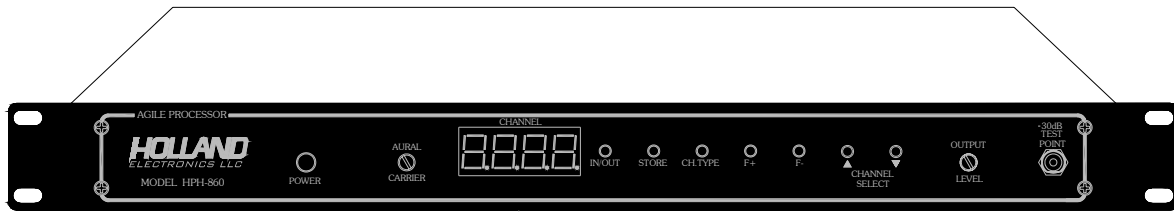

HPH-860

AGILE PROCESSOR

Specifications



Description

The HPH-860 is a frequency agile, microprocessor controlled, heterodyne signal processor which uses the latest low noise, PLL, SAW filter and AGC techniques to provide superior quality and performance at an attractive low price. The HPH-860 has been specifically designed to produce the highest quality pictures at extremely low inputs while maintaining stable output levels with its sync tip AGC

circuit. High input capability and SAW filtering provide the unit with the ability to process a single cable channel even in the presence of adjacent channels. High frequency and extremely high accuracy Phase Locked Loop oscillators allow the unit to meet the frequency offset and stability requirements of FCC Docket 21006.

Features

- Microprocessor controlled
- High output : 60 dBmV, 57 dBmV minimum
- SAW filtered
- Spurious outputs down >-60 dB
- Adjacent channel rejection of -60 dB
- Superior low noise circuitry
- Sync tip AGC for precise signal regulation
- BTSC stereo compatible
- 45.75 MHz IF loop-thru
- Output capability to 860 MHz
- Five year limited warranty

Specifications

Input Frequency Range:	54 to 806 MHz
Input Channels:	CATV channels 2 to 125 Off-air channels 2 to 69
Output Frequency Range:	54 to 860 MHz
Output Channels:	CATV channels 2 to 94, 95-99, 100-135
Output Level:	57 dBmV min.
Input Range:	0-30dBmV typ.
Output Level Adjust Range:	48 to 60 dBmV
Aural Carrier Adjust Range:	12 dB min.

Noise Figure:	8 dB VHF, 10 dB UHF
Spurious Outputs:	
In-band	>-57 dB min, -60dB typ.
Fv-1.5 MHz	>-50 dB
Out of Band	> -57dB min, -60dB typ.
Video Flatness:	± 1.7 dB
IF Output:	35 ± 2 dBmV @45.75 ± .005 MHz
Controls:	Aural Carrier and Output Level
Weight:	7.9 lbs.
Size:	19" L x 1 ³ / ₄ " H x 10" D
Power Requirements:	90 - 260 VAC, 60 Hz

Front & Rear Panels

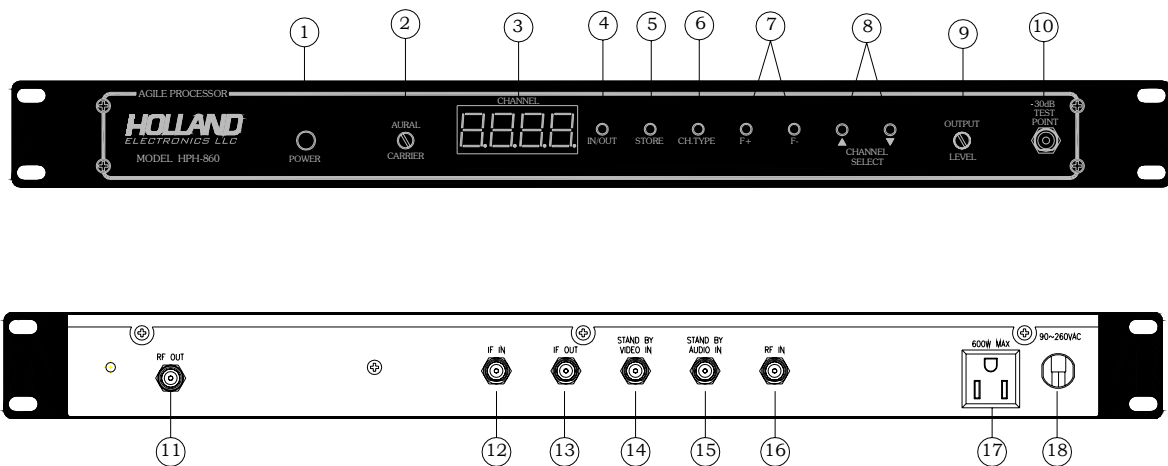

1. Power On LED:

Indicates power is on when lit.

2. Aural Adjust :

Use to set level of audio carrier (volume).

3. Channel Display :

Displays input and output channels, channel mode, and fine tune frequency increments.

4. IN/OUT :

Toggles between the input and output channels.

5. Store :

Press this button to store current programming information in the non-volatile memory.

6. Channel Type :

Use to select standard, HRC, IRC or off-air channels.

7. F+ / F- :

Use these buttons to fine tune the frequency. When either button is pressed, the frequency is increased (F+) or decreased (F-) by 12.5 KHz from the current frequency.

8. CH▲▼:

Use these buttons to select desired channel.

9. Output Adjust :

Use to set level of RF output.

10. -30 dB Test Point :

Used to monitor input level.

11. RF Out :

Connect this port to distribution system.

12. IF In :

Input from I.F. scrambler or I.F. output.

13. IF Out :

To I.F. input or scrambling device.

14. Video In (Stand-by input) : (Option)

Connect to baseband video source for stand-by operation.

15. Audio In (Stand-by input) : (Option)

Connect to baseband audio source for stand-by operation.

16. RF In:

Connect RF source (antenna or cable) to this port.

17. Convenience outlet :

Provides 90 ~ 260 Vac, 60Hz, 600W max. supply.

18. Power Cord:

Standard three wire, U.S.A. type.

CHANNEL SELECTION AND TUNING.....

INPUT CHANNEL MODE SELECTION

Press the **IN/OUT** button to select input channel.
Press until a "I" appears in the left hand side of the display.

Press the **CHANNEL SELECT** button to select the desired input channel.

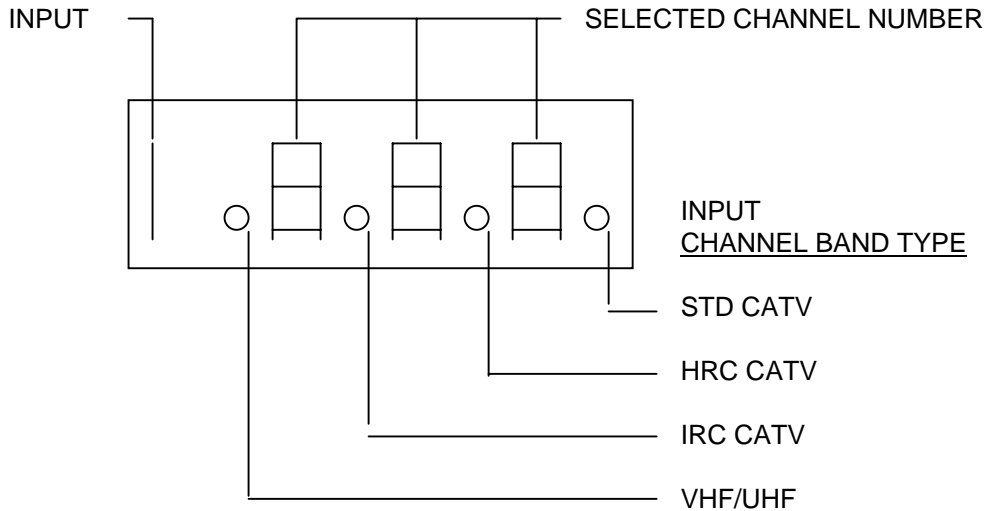

Press the **CHANNEL TYPE** button until the desired input channel band is selected. Press the STORE button to save the selected input channel to memory.

OUTPUT CHANNEL MODE SELECTION

Press the **IN/OUT** button to select the desired output channel. Press until a "U" is displayed on the far left side of the display.

Press the **CHANNEL SELECT BUTTON** to select the desired output channel.

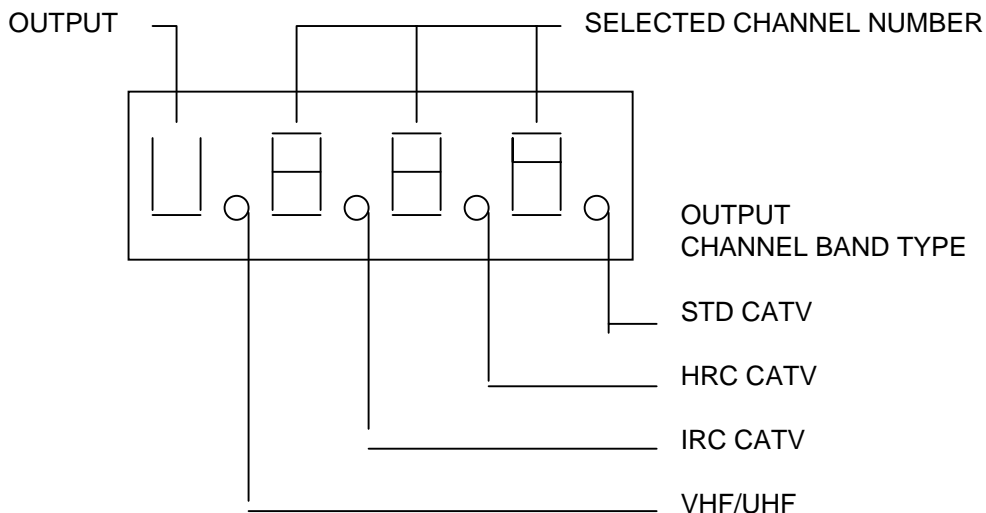

Press the **CHANNEL TYPE** button until the desired output channel band is selected as indicated with the illuminated decimal points on the display**. Press the **STORE** button to save the selected output channel in memory.

** Press the **F+ or F-** buttons to program the unit for a 12.5 KHz offset on STD CATV channels 14-16, 25-41, 43-53 and the 25 KHz offset for STD CATV channels 42, 98 and 99 as specified by the FCC for these aeronautical channels.
F+ and F- are in 12.5 KHz increments.

Installation Procedure

1. Connect the I.F. jumper from the I.F. output to the I.F. input on the HPH-860 rear panel.
2. Insert power plug into a surge protected 90 - 260 VAC outlet. Observe the lit POWER LED light indicating power is on.
3. Connect a spectrum analyzer or field strength meter to the processor RF OUT port.
4. Connect RF signal source to RF IN port. Signal level should be ~5 – 25 dBmV.
5. Set the HPH-860 desired input channel Mode and Number. (see page 4)
6. Set the HPH-860 desired output channel Mode and Number. (see page 4)
7. Turn the OUTPUT LEVEL adjustment on the front panel of the processor to get the desired output level.
8. Turn the AURAL CARRIER adjustment to set the audio carrier 12 - 17 dB below the video carrier.
9. Remove the analyzer or field strength meter from the processor RF OUT port.
10. Connect the processor RF OUT port to a television/monitor. (Make sure to use the proper size attenuator between the processor and the television/monitor in order to avoid overdriving the television/monitor.)
11. Verify that the television/monitor picture is of good quality for viewing.
12. Remove the television/monitor and attenuator from the processor RF OUT port.
13. Connect the processor RF OUT port to the RF input of the head-end system.

IMPORTANT!!

WARNING: Holland Electronics does NOT represent this product to be WATERPROOFED. To reduce risk of electrical shock, fire hazard, or damage to the unit, do not expose to rain or moisture.

CAUTION: To prevent electric shock, do not use this plug with an extension cord, receptacle or other outlet unless the blades can be fully inserted to prevent blade exposure.

NOTE TO INSTALLER: This reminder calls the system installer's attention to Article 820-22 of the NEC that provides guidelines for proper grounding and, in particular, specifies that the cable ground shall be connected to the grounding system of the building, as close to the point of cable entry as practical.

**WARNING:
TO PREVENT FIRE OR ELECTRICAL SHOCK, DO NOT EXPOSE THIS UNIT TO RAIN OR MOISTURE**

.....

HOLLAND ELECTRONICS LLC LIMITED WARRANTY

Holland ELECTRONICS LLC, warrants that the product enclosed with this Limited Warranty statement will conform to the manufacturer's specifications and be free of defects in the workmanship and material for a period of five years (5) from the date of original purchase.

WARRANTY PROCEDURE:

If the product appears to be defective contact Holland Electronics LLC at (805) 339-9060. We will analyze the problem and offer solutions to prevent removing the unit from service. If the unit is to be returned for evaluation, you will be issued a Return Material Authorization (RMA) number.

Holland Electronics LLC will, at its option, repair or replace the defective unit, under warranty, without charge for parts or labor. This repair will be subject to charges if signs of tampering or misuse are detected. Incoming shipping costs will be the customer's responsibility. Returns will not be accepted without an RMA number.

The warranty and remedy provided above are exclusive and in lieu of all other express warranties and unless stated herein, any statements or representations made by any other person or firm are void. The duration of any implied warranties of merchantability or fitness for a particular purpose on this product shall be limited to the duration of the express warranty set fourth above. Except as provided in this written warranty, Holland Electronics LLC shall not be liable for any loss, inconvenience, or damage, including direct, special, incidental, or consequential damages, resulting from the use or inability to use this product, whether resulting from breach of warranty or any other legal theory.

Some states do not allow limitations on how long an implied warranty lasts and some states do not allow the exclusion or limitation of incidental or consequential damages, so the above limitation and exclusion may not apply to you.

This warranty gives you specific legal rights, and you may also have other rights which vary from state to state.

To arrange for Warranty Service: Call Holland Electronics LLC (805) 339-9060